

Product: ACOUSTIC, LUMINOUS, HANGED KITE

Kite is a hanged sound-absorbing panels system. It's used in different contexts, from open space office to meeting rooms, to all those public spaces where sound performance prevents proper use of the environment. Furthermore, the possibility of a LED bar turns *Kite* into a lighting element that enhances function and use.

STRUCTURE

Panels, suspended from the ceiling thanks to a system of Steel cables, are composed of a supporting frame in Aluminium and a core of semirigid expanded Polyethylene. The panel, thanks to this particular morphology, becomes an excellent acoustic trap characterized by a high sound absorption.

ACOUSTIC PERFORMANCE

The acoustic performed in the laboratory on the hanging lamp *Kite*, according to EN ISO 354 shows that between 250 and 2000 Hz, typical frequency range of human speech, the performance of absorption is at the highest level: the acoustic performance does not vary over time as it does not degenerate or charge due to the humidity of the environment. The material also is self-extinguishing in class 1.

The performance of *Kite* panels, in accordance with the regulation UNI EN ISO 354 has an average value of absorption of 0,9 for the frequency between 1.000 and 2.000 Hz.

CEILING FIXING

A system of Steel cables ensures fixing to the ceiling.

LIGHTING

The insertion of a luminaire LED in the central part of the panel adds to lighting functions.
Strip LED 24V DC, color temperature 3000° K.
Power source 100V-277AC, 50/60Hz

PLEASE NOTE: lamps are NOT supplied with dimming system.

FINISHES

The product is upholstered with stretch SPRINT fabric.
COMPOSITION: 100% Polyester; 328 g/sqm; resistance to abrasion > 100.000 Martindale cycles; fire resistance BS EN 1021 – 1:2006, BS EN 1021 – 2:2006, BS 7176:2007.

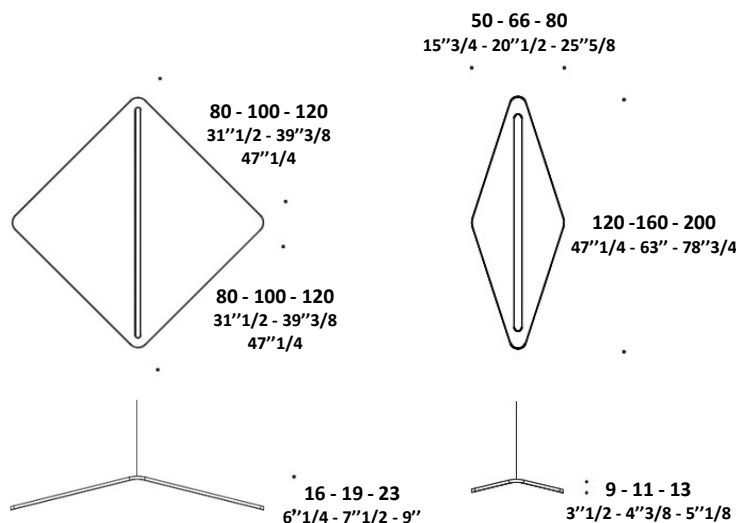

Product: ACOUSTIC, LUMINOUS, HANGED KITE

REVERBERATION CHAMBER TEST IN ACCORDANCE TO EN ISO 354 th. 30

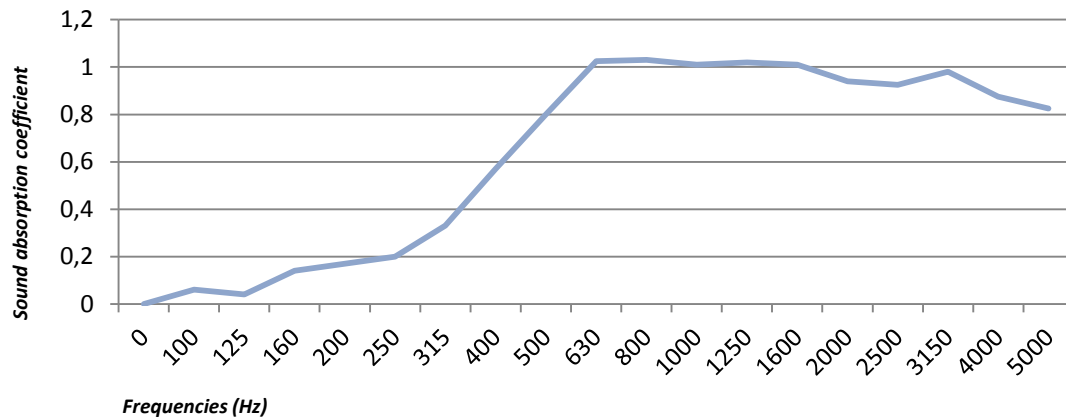

ELECTRIFICATION

model	LED power	supply	color	emission
KITE 80	1 X Max.46W	24VDC	3000K	100% DIRECT
KITE 100	1 X Max.60W	24VDC	3000K	100% DIRECT
KITE 120	1 X Max.74W	24VDC	3000K	100% DIRECT

Product: ACOUSTIC, LUMINOUS, HANGED KITE

PHOTOMETRIC CURVES GRAPH (KITE 80X80 CM)

820mm x 820mm

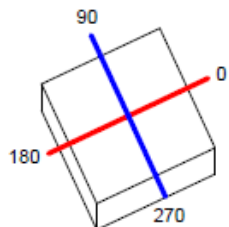

Half-planes C

180.0 — 0.0

270.0 — 90.0

ULOR 0.00 %
DLOR 100.00 %
RN 0.00 %

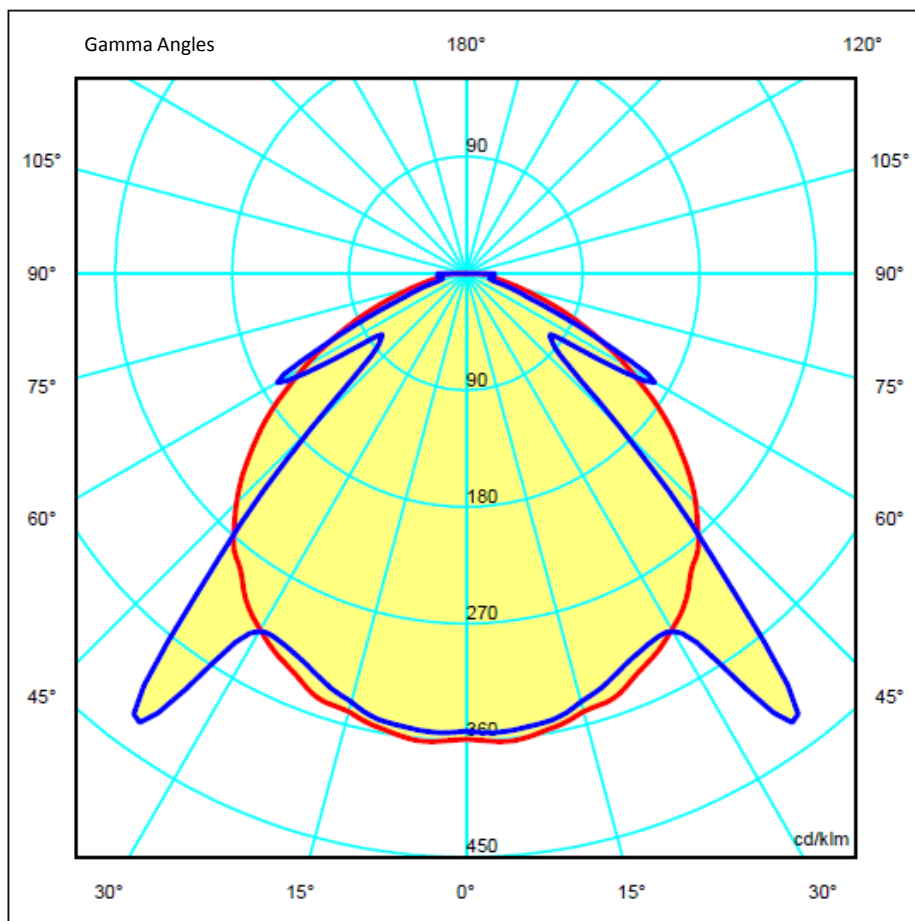

Product: ACOUSTIC, LUMINOUS, HANGED KITE

PHOTOMETRIC CURVES GRAPH (KITE 80X80 CM)

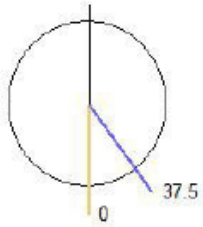

Half-planes C

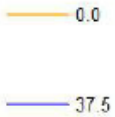

Flux 1598.52 lm
 Maximum 422.67 cd/klm
 Position C=75.00 G=37.50
 Efficiency: 100.00%
 Date: 02-02-2015
 Double Symmetry

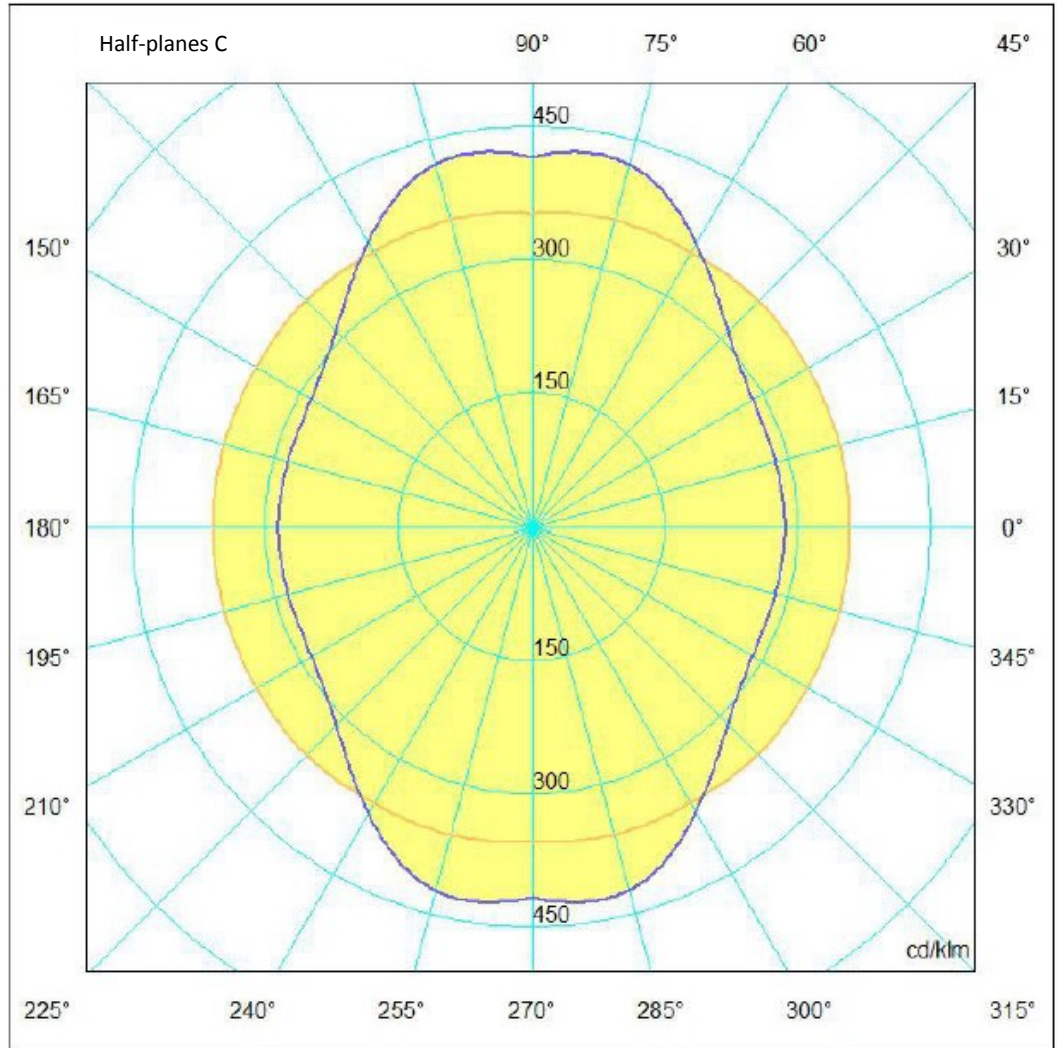

Product: ACOUSTIC, LUMINOUS, HANGED KITE

PHOTOMETRIC CURVES GRAPH (KITE 100X100 CM)

1050mm x 1050mm

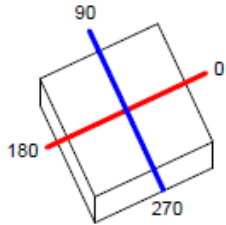

Half-planes C

180.0 — 0.0

270.0 — 90.0

ULOR 0.00 %
 DLOR 100.00 %
 RN 0.00 %

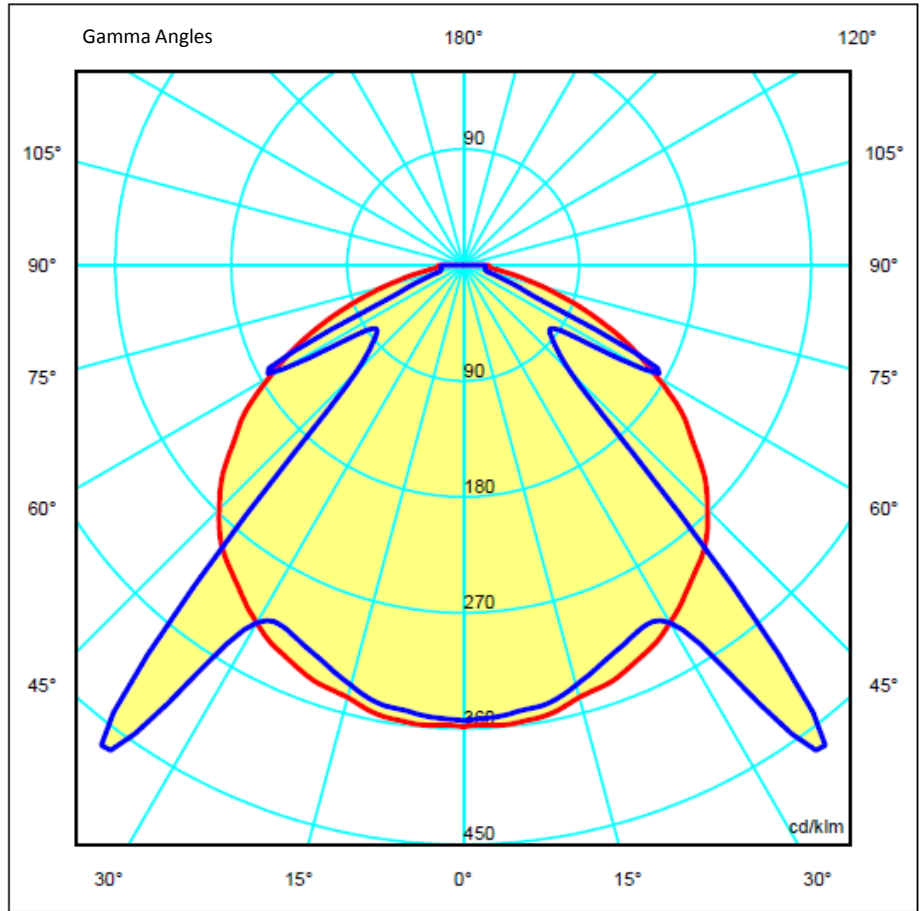

Product: ACOUSTIC, LUMINOUS, HANGED KITE

PHOTOMETRIC CURVES GRAPH (KITE 100X100 CM)

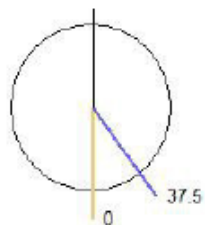

Half-planes C



Flux 2030.71 lm
 Maximum 457.48 cd/klm
 Position C=90.00 G=37.50
 Efficiency: 100.00%
 Date: 02-02-2015
 Double Symmetry

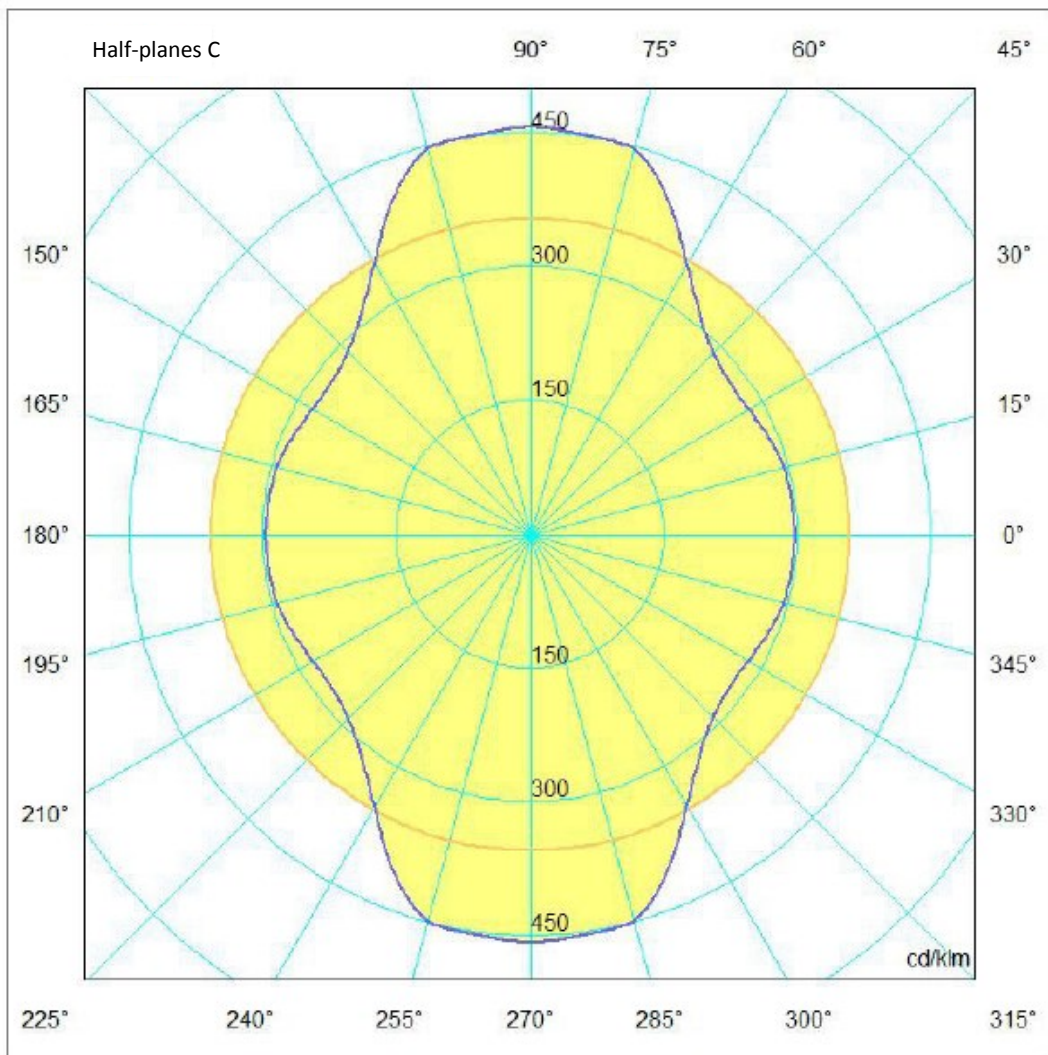

Product: ACOUSTIC, LUMINOUS, HANGED KITE

PHOTOMETRIC CURVES GRAPH (KITE 120X120 CM)

1250mm x 1250mm

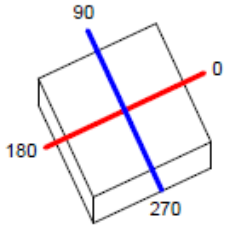

Half-planes C
 180.0 — 0.0
 270.0 — 90.0

ULOR 0.00 %
 DLOR 100.00 %
 RN 0.00 %

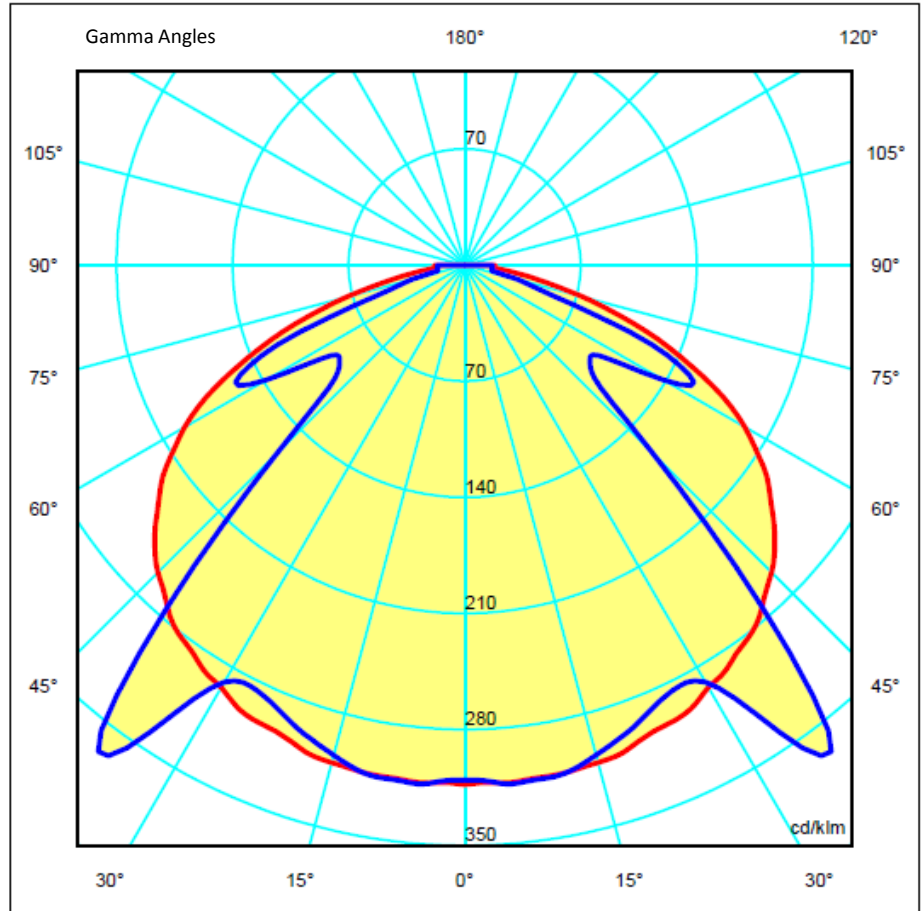

Product: ACOUSTIC, LUMINOUS, HANGED KITE

PHOTOMETRIC CURVES GRAPH (KITE 120X120 CM)

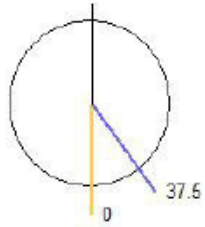

Half-planes C

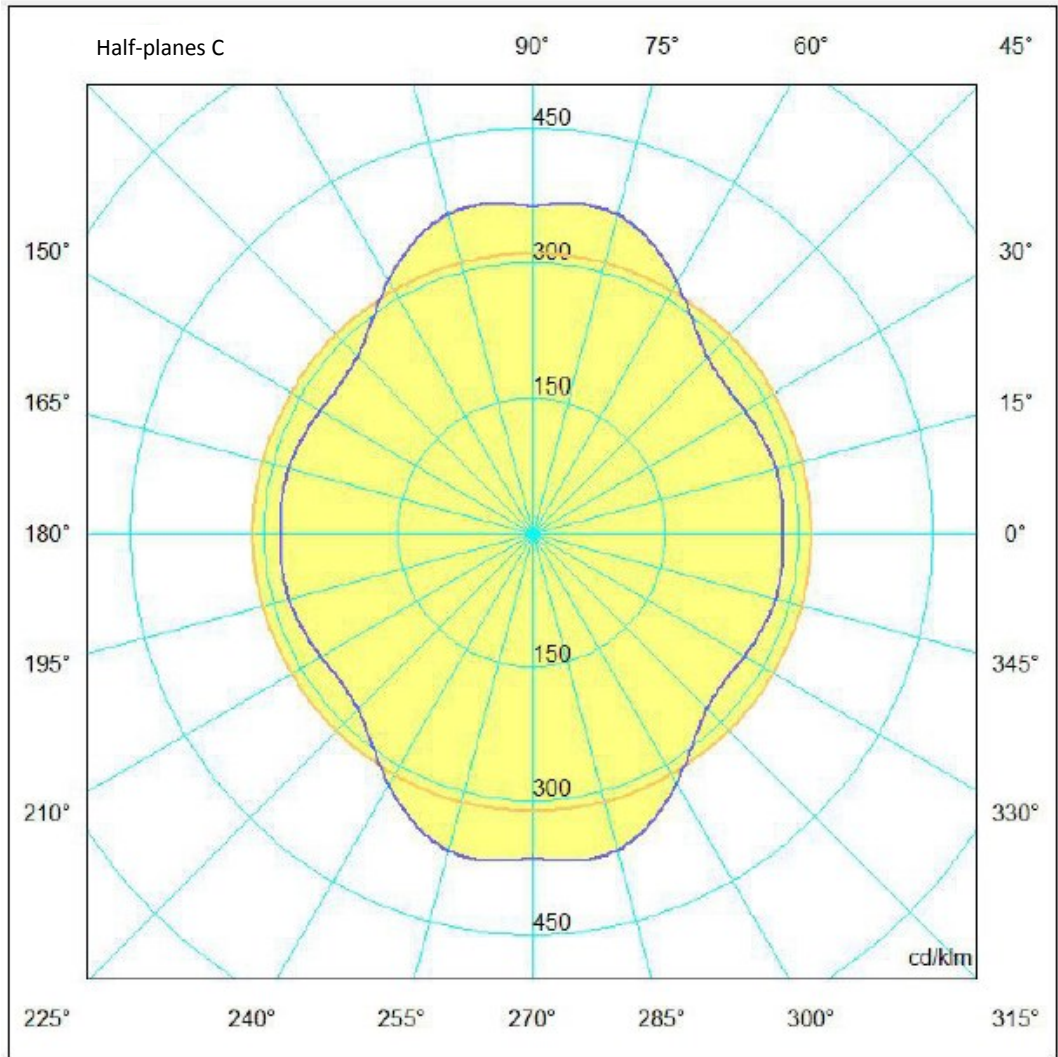
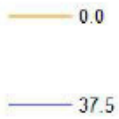

Flux 2713.26 lm
Maximum 367.12 cd/klm
Position C=75.00 G=37.50
Efficiency: 100.00%
Date: 02-02-2015
Double Symmetry

Product: ACOUSTIC, LUMINOUS, HANGED KITE

LIGHTING VALUES AND LUX BEAM WIDTH AT DIFFERENT HEIGHTS

KITE 120x120 CM



KITE 100x100 CM



KITE 80x80 CM



Product: KITE WALL

Kite is a hanged sound-absorbing panels system. It's used in different contexts, open space, meeting rooms, to all those public spaces where sound performance prevents proper use of the environment.

STRUCTURE

Fixed to wall panel are composed of a supporting frame in thermoplastic polymer and a core of semirigid expanded Polyethylene. These panels are then upholstered with a fabric covering.

The panel thanks to this particular morphology becomes an excellent acoustic trap characterized by a high sound absorption.

ACOUSTIC PERFORMANCE

The acoustic tests performed in the laboratory on the hanging lamp Kite, according to EN ISO 354 show that between 250 and 2000 Hz, typical frequency range of human speech, the performance of absorption is at the highest level: the acoustic performance does not vary over time as it does not degenerate or change due to the humidity of the environment.

The material also is self-extinguishing in class 1.

The performance of Kite panels, in accordance with the regulation UNI EN ISO 354 has an average value of absorption α of 0,9 for the frequency between 1.000 and 2.000 Hz.

WALL FIXING

A metal support ensures wall fixing.

FINISHES

The product is upholstered with stretch SPRINT fabric.
 COMPOSITION: 100% Polyester; 328 g/sqm; resistance to abrasion > 100.000 Martindale cycles; fire resistance BS EN 1021 – 1:2006, BS EN 1021 – 2:2006, BS 7176:2007.

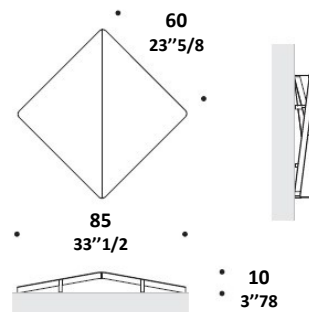

REVERBERATION CHAMBER TEST IN ACCORDANCE TO EN ISO 354 th. 40

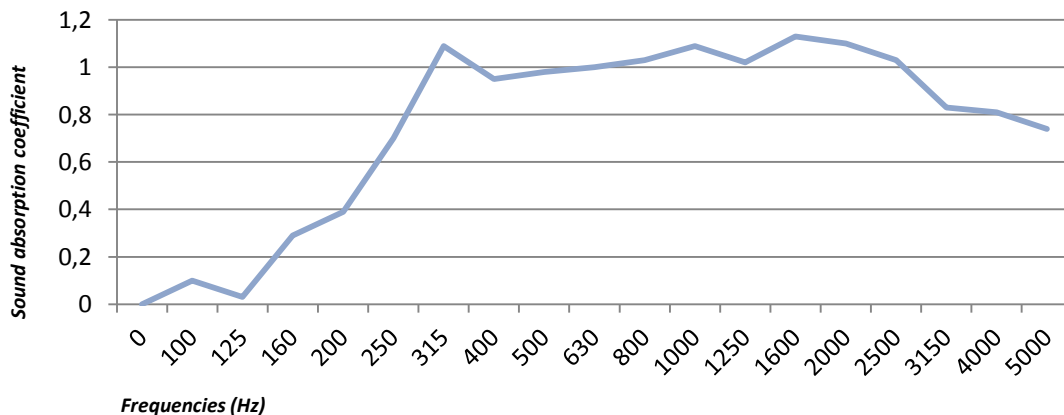

Product: KITE NAKED

The lamp is composed of a supporting frame in Aluminium and of a LED in the central part.

STRUCTURE

The frame is in varnished or polished Aluminium.

CEILING FIXING

A system of Steel cables ensures the suspension to the the ceiling.

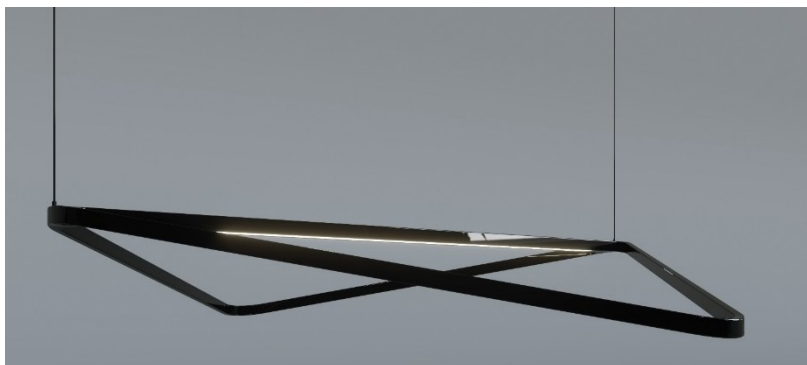

LIGHTING

Strip LED 24V DC, color temperature 3000° K.
Power source 100V-277VAC, 50/60Hz

ELECTRIFICATION

The insertion of a lighting LED element in the central part add to the panel the function as a lamp.

model	LED power	supply	colour	emission
KITE NAKED 60	1 X Max.31W	24VDC	3000K	25% INDIRECT 75% DIRECT
KITE NAKED 80	1 X Max.46W	24VDC	3000K	25% INDIRECT 75% DIRECT
KITE NAKED 100	1 X Max.60W	24VDC	3000K	25% INDIRECT 75% DIRECT
KITE NAKED 120	1 X Max.74W	24VDC	3000K	25% INDIRECT 75% DIRECT

PLEASE NOTE: lamps are NOT supplied with dimming system.

FINISHES

Frame:
Varnished Aluminium: White – Black.
Polished Aluminium.

